

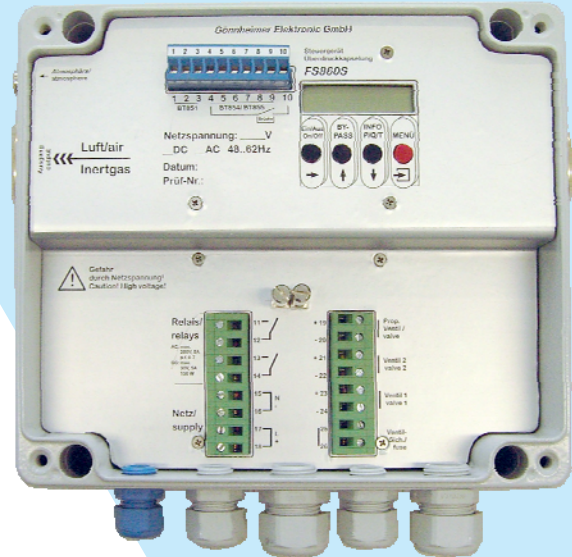
# Pressurized enclosure system F860S

X-Purge according  
EN 60079-2: 2005, EN 50016: 2003  
Standard purging rates > 100 m<sup>3</sup>/h



## Characteristics

- 👉 **Compact system, mounting inside hazardous area or inside Ex p-Enclosure**
- 👉 **Short purging time based on by high flow rates**
- 👉 **ATEX – Certificate DMT 99 ATEX E 003:**
  - Ex p- function test according to EN 50016: 2003 and EN 60079-2: 2005
  - Safety standard fulfills EN 954-1, Cat.3
- 👉 **Menu guided programmable operation modes:**
  - Leakage compensation or continuous flow
  - Proportional or digital solenoid valve
- 👉 **Ex p- system with patented proportional pressure and flow measurement**
  - No ageing membrane switches, no screws or potentiometers to adjust pressure or flow thresholds or purging time !
- 👉 **High availability due to PID- regulated pressures and proportional valve**
  - High reliability caused by constant cabinet pressure
  - No waste of purge medium. Just the minimum quantity to hold the cabinet pressure needed
  - Increasing leakage caused by e.g. enclosure ageing is balanced and therefore system failure is prevented
  - No flow noise and only small gas consumption in combination with solid enclosures
- 👉 **Purging with regulated pressure**
  - No overload of pressure sensitive enclosure parts, like membrane switch panels or windows
  - Exact measurement of purge volume by integration of the outlet- sided gas flow
- 👉 **Display**
  - Menu navigation and messages in clear text
  - Online messages for operation and failure states
  - Permanent pressure and flow monitoring
  - Available languages: German, English, French, Spanish, Dutch
- 👉 **High operation safety**
  - Approved function security acc. to EN 954-1, **category 3 !**
  - Alarm messaging at LC-display
  - In- and outputs for external safety chain



## Description

The FS860S is designed for applications in which large volumes have to be purged within a short time. Main applications are e.g. enclosures of electrical machines (motors) as well as large control cabinets. The 2 inch- technology allows purging rates of 33 liters per second (~ 120 m<sup>3</sup>/h) at low pressure levels inside the Ex p- housing.

Optionally the FS860S can be designed for a pressure range up to 27 mbar, which enables purging rates beyond 120m<sup>3</sup>/h.

It is the first compact electronic purging system, which is able to realize these high purging quantities, with only one (single) integrated output. Thereby the FS860S represents a modern and compact alternative to obsolete pneumatically working purging systems.

The integration of proportionally working valve technology (known from the FS850S) makes the 2 inch-system singular in its purging rate class:

- Pressure regulated purging phase
- Integration of flow while purging
- Pressure regulated normal operation phase with minimum purging gas consumption

Optionally the system can be combined with digitally working inlet valves or blower (fan) compression.

The security level of the FS860S corresponds to the category 3 (EN 954-1). This level is required for all devices inside the Ex zone 1 and 21 compliant to IEC 60079-2 !

Occurring errors lead to a direct alerting at the LC- display. Additionally, alarm inputs for external safety chains as well as an optional, programmable reporting output are implemented.

## Technical Details

		Control unit FS860S
General	Mounting	Inside Ex- area
	Ex-protection	II 2 G, EEx em [ib] IIC T6
	Housing protection class	IP65 (without regard of outlet opening)
Housing	Dimensions	L x H x D: 202 mm x 232 mm x 111 mm
	Material	Aluminum, painted / Ral 7035
Electrical Specifications	Mains	24VDC, 24VAC, 110VAC, 120VAC, 220VAC, 230VAC AC: 48 ...62 Hz
	Power consumption	ca. 2,5 VA (without peripherals)
	Working circuits Terminal 11, 12, 13, 14	AC: U ≤ 250VAC, I ≤ 5A bei cos φ > 0,7 DC: U ≤ 30 VDC, I ≤ 5 A, P ≤ 150 W
	Control circuits Terminal 1..10	Ex protection class: intrinsically safe EEx ib IIC see declaration of conformity for further details (DMT 99 ATEX E 003)
Pneumatic	Pressure range	Standard: 0 ... 18 mbar      Optional 0 ... 27 mbar
	Flow rate range	Depending on orifice plate, see table below
Mounting	Ambient temperature	-20°C ...+50°C at T6      -20°C ...+60°C at T4
	Humidity	5-95%, non-condensing
Ex p Configuration	Parameter input	LC-Display, menu guided Different languages : German, English, French, Spanish, Dutch

### Fuse for solenoid valve

(Ex- version)			nominal	Order. Nr.
U <sub>Nominal</sub>	SVP.12	SVD.X	100 mA	<b>SI850.0</b>
			160mA	<b>SI850.1</b>
230 VAC, 220 VAC	100mA	100mA	200 mA	<b>SI850.2</b>
			315 mA	<b>SI850.3</b>
120 VAC, 110 VAC	200 mA	160mA	500 mA	<b>SI850.4</b>
			630 mA	<b>SI850.5</b>
24 VAC, 24 VDC	1,0 A	630mA	1000 mA	<b>SI850.6</b>
			1600 mA	<b>SI850.7</b>
			2000mA	<b>SI850.8</b>

### Flow rates using SVD.L.X

Depending on prepressure and effectively nozzle

x mm	Flow [l/s]		
	2 bar	4 bar	6 bar
6 mm	13,5	20,7	26,6
8 mm	24,0	36,8	46,3
10 mm	37,5	57,5	72,3

### Flow span of the orifice plates

plate orifice	Flow	
	l/s	m³/h
25	8- 18	29- 64
30	13- 33	46- 120

### Type codes

- Control unit FS860S

Control unit FS860S		
Mains:	230 VAC.....	.0
	120 VAC .....	.2
	110 VAC .....	.3
	24 VDC .....	.6
Orifice plate:	25 mm .....	.25
	30 mm .....	.30

Additional orifice plates and flow rates on demand

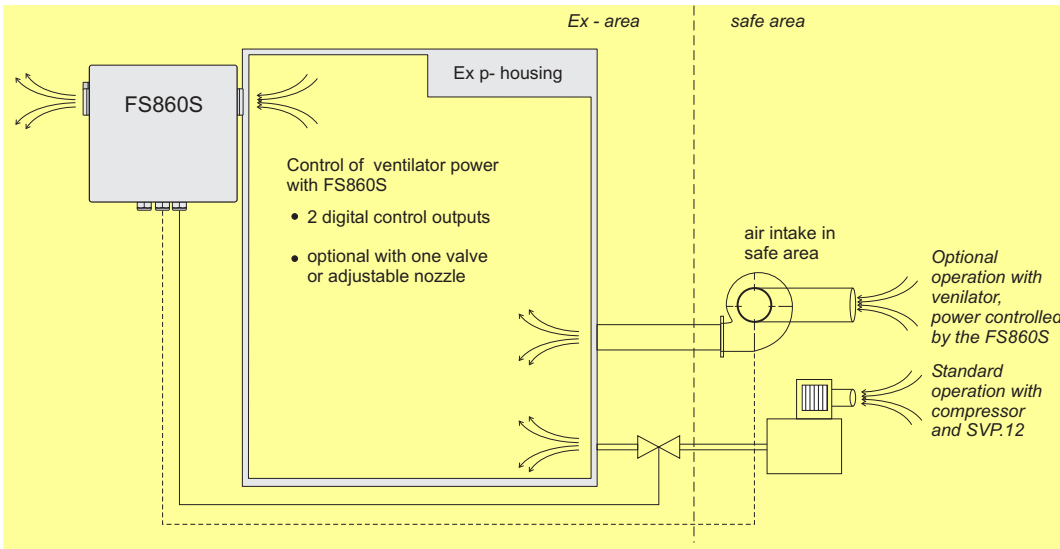
- Solenoid valves

Proportional working solenoid valve SVP Prepressure 0,5.. 6 bar	.12
Digital working solenoid valve SVD	.x
Nozzle: 6 mm .....	.6
8 mm .....	.8
10 mm .....	.10

- Operation panels

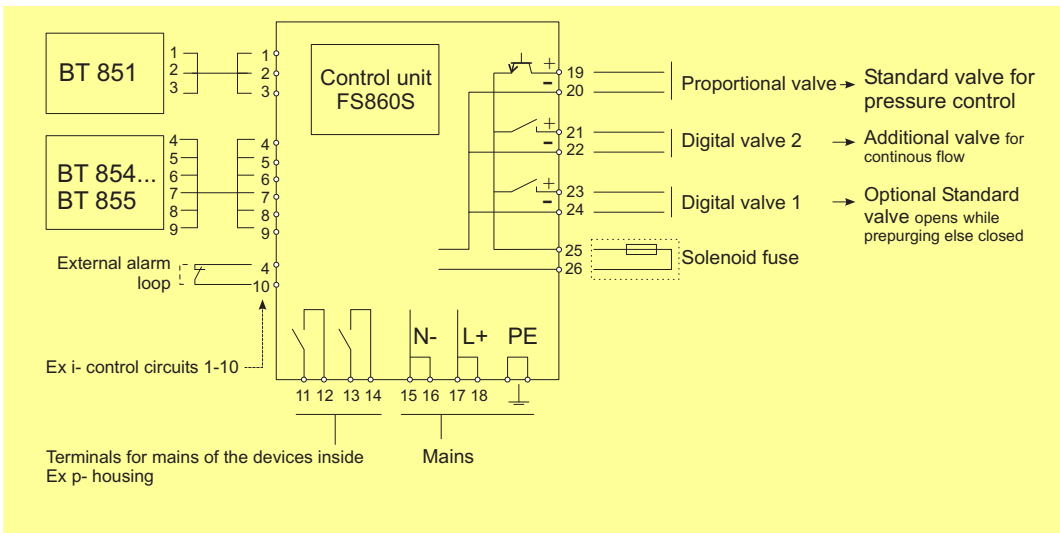
Operation panel	BT
Intelligent operation panel, Ex ib IIC T6, for flush mounting .....	<b>BT851.0</b>
with IP65 housing .....	<b>BT851.5</b>
Operation panel, Ex ib IIC T6, for flush mounting .....	<b>BT854.0</b>
with key switch .....	<b>BT854.1</b>
Operation panel, Ex ib IIC T6, with IP65 housing .....	<b>BT855.0</b>
with key switch .....	<b>BT855.1</b>

# Application



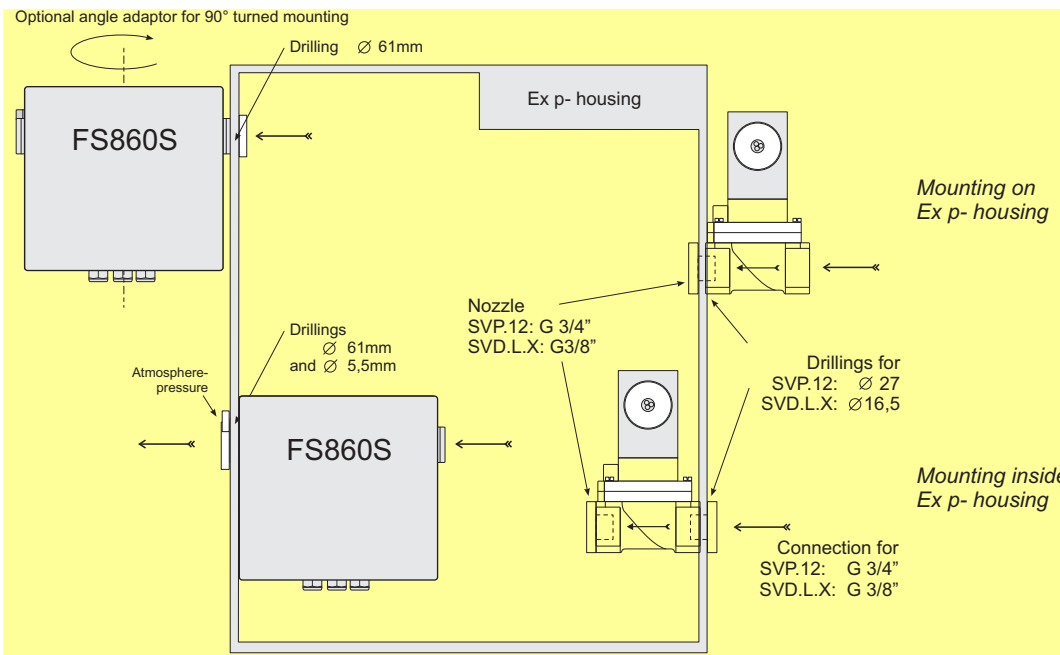
**Figure 1:**  
Application

# Block diagram



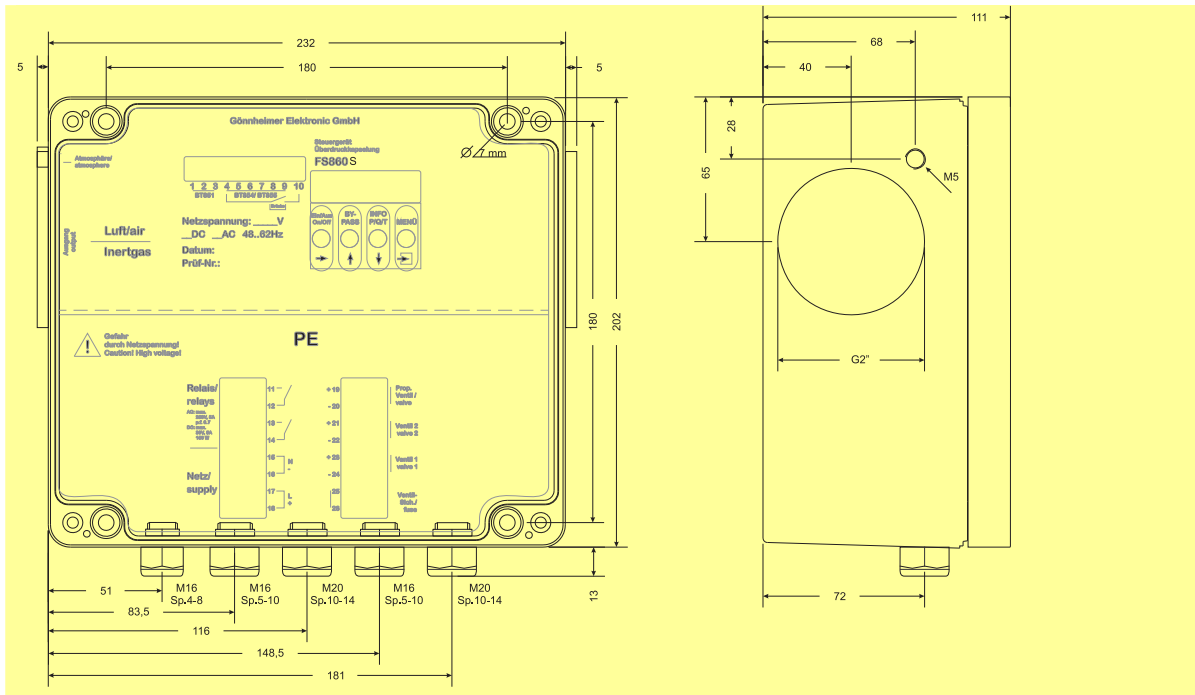
**Figure 2:**  
Electrical Block diagram

# Examples for mounting

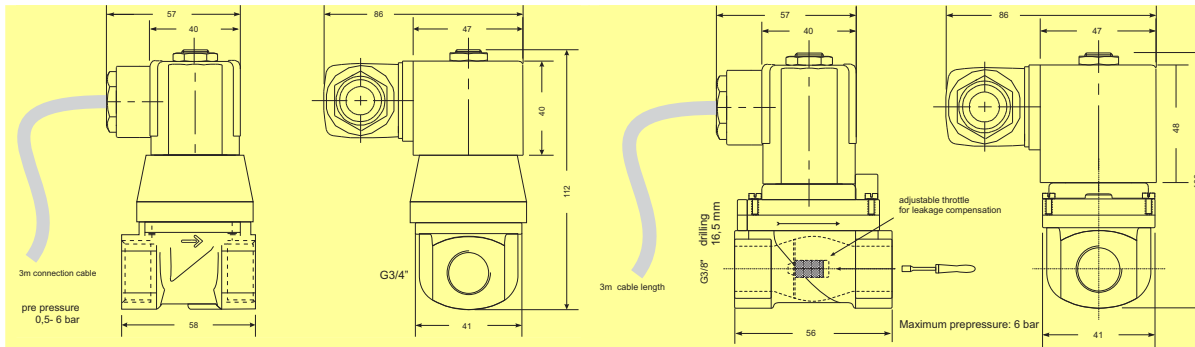


**Figure 3:**  
Examples for mounting

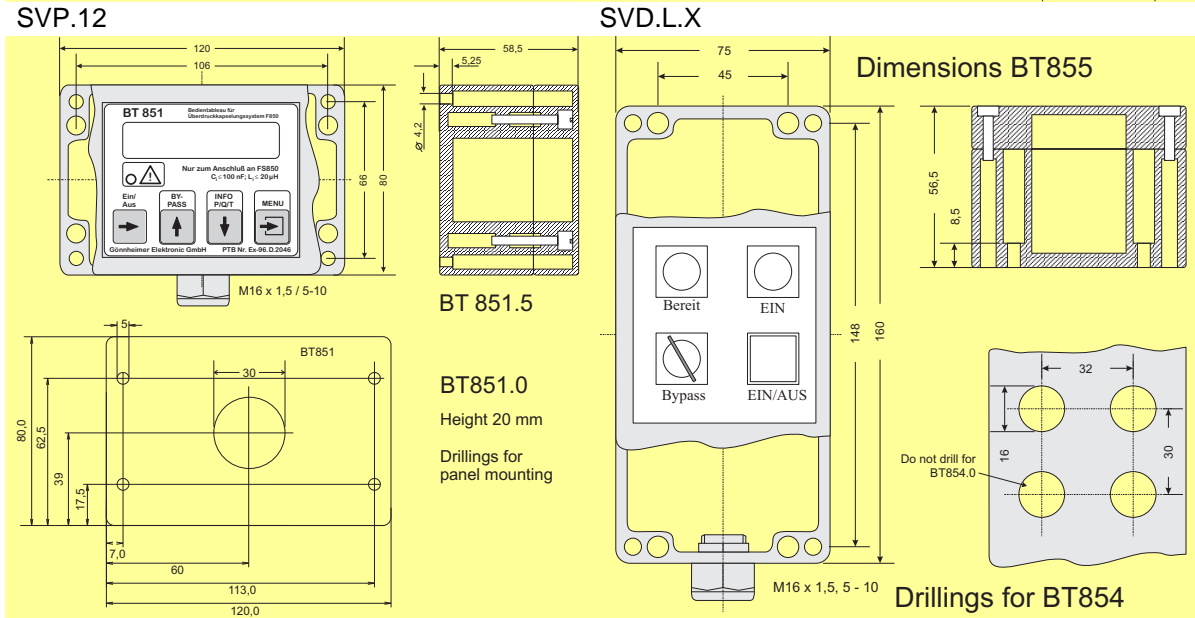
# Dimensions



**Figure 4:**  
**Dimensions**  
**FS860S [mm]**



**Figure 5:**  
**Dimensions**  
**Solenoid**  
**valves [mm]**



**Figure 6:**  
**Dimensions**  
**Operator**  
**panels [mm]**

BT851.x

BT85x.x



## Gönnheimer Elektronik GmbH

http://www.goennheimer.de Email: info@goennheimer.de

Zertifiziert



Dr.-Julius-Leber-Straße 2  
67433 Neustadt/Weinstraße  
Postfach 10 05 07  
67405 Neustadt  
phone: +49 (6321) 49919- 0  
fax: +49 (6321) 49919 - 41